

Dimplex

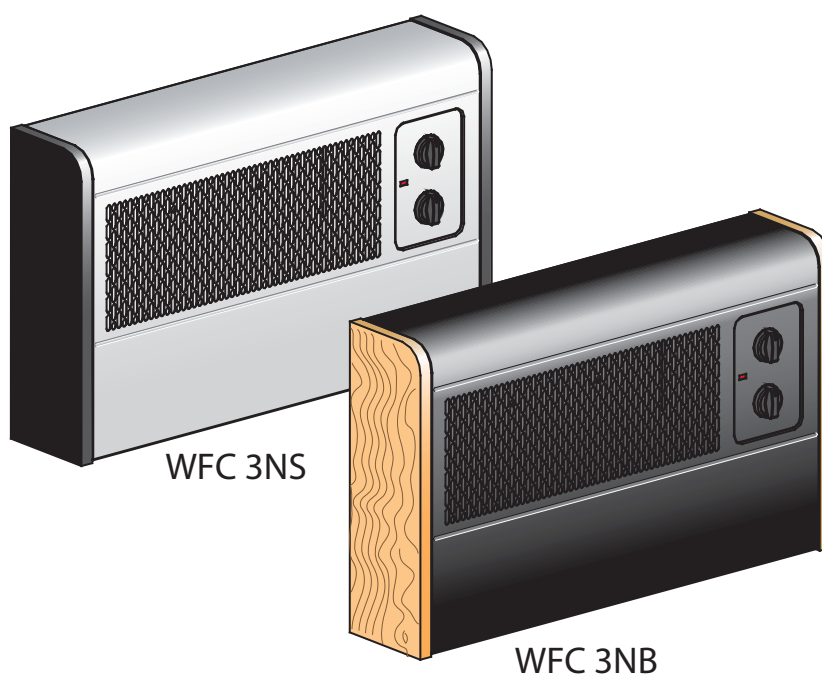

UK

1

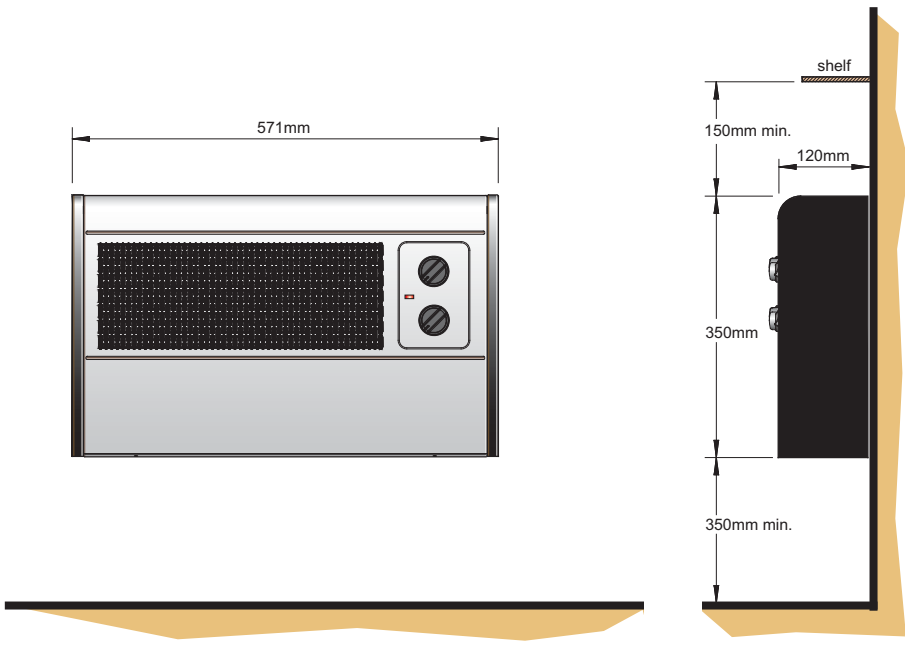

2

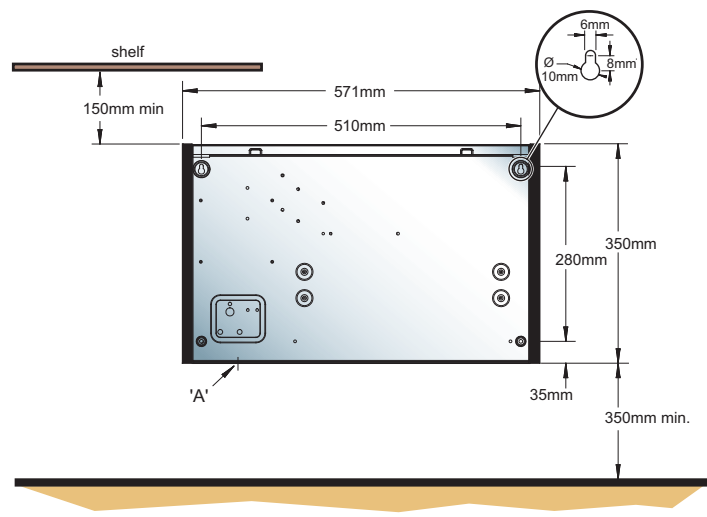

3

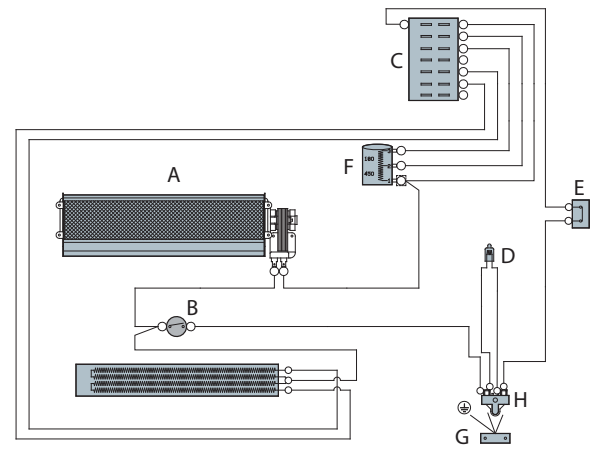

4

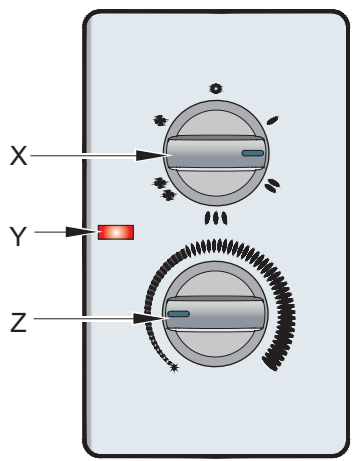

5

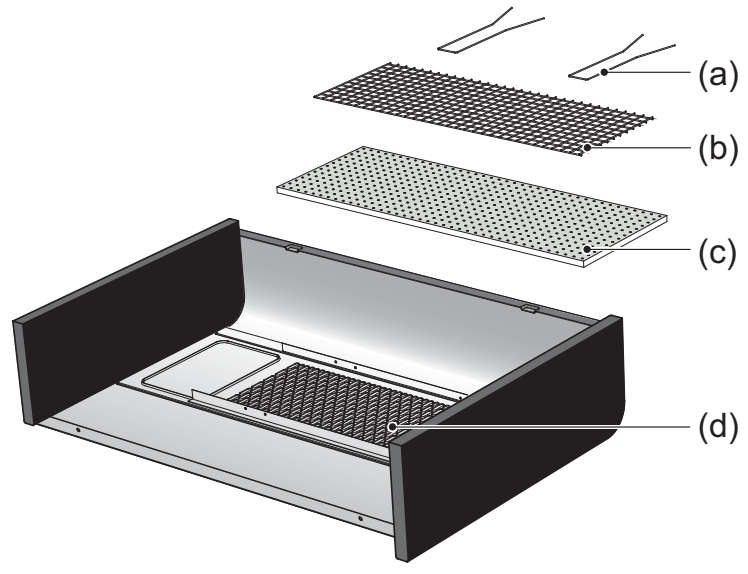

IMPORTANT SAFETY ADVICE

WARNING – THIS APPLIANCE MUST NOT BE USED IN A BATHROOM.

WARNING – DO NOT USE THIS HEATER IN THE IMMEDIATE SURROUNDINGS OF A BATH, A SHOWER OR A SWIMMING POOL.

WARNING – THIS HEATER MUST NOT BE LOCATED IMMEDIATELY BELOW A FIXED SOCKET OUTLET.

DO NOT USE THE HEATER UNTIL IT IS WALL MOUNTED CORRECTLY.

The heater carries a warning 'Do Not Cover' to alert the user to the risk of overheating that exists if the heater is accidentally covered.

NEVER cover or obstruct in any way the air inlet slots at the front of the heater or the heat outlet slots in the base of the heater.

Keep combustible materials such as drapes and other furnishings clear from the front of the heater. Do not use heater to dry your laundry.

This appliance is not intended for use by children or other persons without assistance or supervision if their physical, sensory or mental capabilities prevent them from using it safely. Children should be supervised to ensure that they do not play with the appliance.

If young children, the aged, or infirm are likely to be left in the vicinity of the heater, we advise that adequate precautions should be taken. We recommend that a guard be fitted to ensure contact with the heater is avoided and objects cannot be inserted into the product.

Caution: In order to avoid a hazard due to inadvertent resetting of the thermal cut-out, this appliance must not be supplied through an external switching device, such as a timer, or connected to a circuit that is regularly switched on and off by the utility. Do not use where excessive dust or moisture is present.

For further information, please contact our guard supplier direct on Tel. No. 01603 667957, or in the case of difficulty or for further advice contact the Customer Helpline.

Installation

Before undertaking installation work, ensure the electricity supply is disconnected from any relevant fixed wiring.

Supply cable is not provided with this appliance, and a competent electrician should therefore install it.

The appliance must be fitted horizontally with the cable or conduit entry at bottom right. It should be mounted such that the underside is at least 350mm above the floor and the top of the heater is 150mm below any overhanging shelf or obstruction.

This heater must be used on an A.C.~ supply only and the voltage marked on the heater must correspond to the supply voltage.

To comply with the I.E.E. Wiring Regulations, the appliance must be earthed; the supply circuit must be adequate for the input of the appliance, and the circuit protected by a suitable 13A fuse. A suitable termination to the fixed wiring of the premises must be provided adjacent to the final position of the appliance. In this instance, such a termination can be a double-pole switch with a contact separation of at least 3mm in all poles.

The heater must not be located immediately below a fixed socket-outlet.

Electrical

WARNING: THIS APPLIANCE MUST BE EARTHED.

After ensuring the electricity supply is not live, electrical connections can be made, either to an adjacent double-pole switch having a contact separation of at least 3mm in all poles or to a plug-top for use in a standard 13A socket. If the latter:

Connect **Green and Yellow** wire to plug terminal marked **E** or  **Green or Green and Yellow**. Connect **Blue** wire to plug terminal marked **N** or **Black**. Connect **Brown** wire to plug terminal marked **L** or **Red**.

Refit cover, first hooking top over the back of the unit and then securing the bottom by refitting the two screws under the bottom edge. The appliance is now ready for use and the electricity supply can be reinstated.

Procedure

Release the front cover from the unit by undoing the two screws under the bottom edge.

Carefully remove cover by pulling bottom-front forward, and then lift to release top from retaining slots.

Mark screw fixing positions on wall in accordance with the dimensions shown on the diagram in Fig 2. The unit must be secured to the wall with four screws through the holes provided. The two upper holes are keyhole shaped to enable the two upper screws to be positioned first. The unit can then be hung on these screws while the two lower screws are positioned. Before finally tightening all four screws, ensure the unit is truly horizontal.

Fit a 3 core 1.5 square millimetre flexible cord through the cable entry bush, connect wires to the appropriate terminals and tighten cable clamp. Alternatively the heater may be connected with conduit through the base after removing the knockout containing the cable entry bush (see 'A' in Fig. 2).

Wiring

See Fig. 3 for Wiring Diagram layout.







Component

- A. Cross flow fan
- B. Cut-out
- C. Selector switch
- D. Neon light
- E. Thermostat
- F. Resistor
- G. Earth Terminal
- H. Terminal Block
- J. Cable Clamp

Operation

The Dimplex WFC 3NB and WFC 3NS have a total loading of 3Kw. They are fitted with two control knobs (see 'X' and 'Z' on Fig. 4) and a pilot light (see 'Y' on Fig. 4). The air inlet is in the front panel, and the outlet on the underside.

The upper knob 'X' operates a six-position switch, giving a choice of operating characteristics as follows :

	Off
	1Kw of heat, low fan speed
	2Kw of heat, medium fan speed
	3Kw of heat, high fan speed
	Fan only, low speed
	Fan only, high speed

The lower knob (see 'Z' on Fig. 4) operates a thermostat which enables the temperature of the room to be regulated.

The pilot light (see 'Y' on Fig. 4) indicates when the appliance is connected to the electricity supply.

Additionally, a cut-out is incorporated in the unit which will switch the electricity supply off if for any reason the appliance overheats.

To control the room temperature, set the mark on the thermostat knob to the required temperature on the visually graduated scale (see 'Z' on Fig. 4). The thermostat will monitor continuously the temperature of the air returning to the inlet grille, and the heater element(s) selected will achieve or maintain the chosen temperature level efficiently and economically.

When running Fan only modes, rotate thermostat knob 'Z' fully clockwise to ensure continuous cool air.

Thermal Safety Cut-out

For your safety, this appliance has been fitted with thermal cut-out. In the event that the product overheats, the cut-out switches the heat off automatically.

To bring the heat back into operation, remove the cause of the overheating, then unplug or turn off the electrical supply to the heater for up to 10 minutes.

When the heater has cooled sufficiently, re-connect and switch on the heater. If the cut-out operates repeatedly, contact your supplier.

To control the room temperature, set the mark on the thermostat knob to the required temperature on the visually graduated scale (see Fig. 4). The thermostat will monitor continuously the temperature of the air returning to the inlet grille, and the heater element(s) selected will achieve or maintain the chosen temperature level efficiently and economically.

When running Fan only modes, rotate thermostat knob to 'max.' position to ensure continuous cool air

General Cleaning

WARNING: BEFORE UNDERTAKING ANY MAINTENANCE OR CLEANING WORK ON THE APPLIANCE, IMMEDIATELY DISCONNECT THE ELECTRICITY SUPPLY EITHER BY SWITCHING OFF AT THE ADJACENT DOUBLE POLE SWITCH OR BY REMOVING THE PLUG FROM THE SOCKET.

The outside of the appliance should be wiped over with a soft damp cloth and then dried. Do not use detergents or abrasives.

The filter should be cleaned by gently passing the soft brush attachment of a vacuum cleaner over the front grille (see 'd' - Fig. 5).

Service and Repair

THE INTERNAL CLEANING AND MAINTENANCE WORK SHOULD ONLY BE UNDERTAKEN BY COMPETENT PERSONS WITH EXPERIENCE OF REPAIRING DOMESTIC ELECTRICAL APPLIANCES AND IN FULL KNOWLEDGE OF THE POSSIBLE HAZARDS INVOLVED.

To ensure the appliance operates efficiently, the following maintenance should be undertaken periodically. The cover should be removed and refitted as detailed under 'Procedure'.

- **Fan Blades** : These should be cleaned by using the soft brush attachment of a vacuum cleaner. Care should be taken not to damage the blades.
- **Filter** : The filter (see 'c' - Fig. 5) can be removed completely for cleaning, but generally provided this is cleaned frequently as detailed above, this should not be necessary. Where removal of filter is required for cleaning, the filter retaining wires (see 'a' - Fig. 5) can be removed, allowing the mesh (see 'b' - Fig. 5) and the filter to be taken out .
- **General** : With the cover removed, opportunity should be taken to remove any accumulations of dust from within the unit.
- **Bearings** : Fan and motor bearings should be given one or two (not more) drops of low viscosity oil (e.g. sewing machine oil) approximately every 12 months.

Recycling



For electrical products sold within the European Community.

At the end of the electrical products useful life it should not be disposed of with household waste. Please recycle where facilities exist. Check with your Local Authority or retailer for recycling advice in your country.

After Sales Service

Your product is guaranteed for one year from the date of purchase.

Within this period, we undertake to repair or exchange this product free of charge (excluding lamps & subject to availability) provided it has been installed and operated in accordance with these instructions.

Your rights under this guarantee are additional to your statutory rights, which in turn are not affected by this guarantee.

Should you require after sales information or assistance with this product please go to www.dimplex.co.uk where you will find our self help guide by clicking on "After Sales" or ring our helpdesk on 0845 600 5111 (UK) or 01 842 4833 (R.O.I.) Spare parts are also available on the website www.dimplex.co.uk

Please retain your receipt as proof of purchase.

Dimplex UK Limited
Millbrook House
Grange Drive
Hedge End
Southampton
Hampshire. SO30 2DF

www.dimplex.co.uk

Republic of Ireland Tel. 01 8424833